

SV-(DLE) 10../604
Safety Shutoff Valve
Installation Instructions

SPECIFICATIONS

- SV/604** Normally closed automatic shutoff valve with proof of closure. Fast opening, fast closing.
- SV-DLE/604** Normally closed automatic shutoff valve with proof of closure. Slow opening, fast closing. Valve features adjustable max. flow and adjustable initial lift.

Body size Size (NPT)

SV / SV-DLE 1005/604	1/2"
SV / SV-DLE 1007/604	3/4"
SV / SV-DLE 1010/604	1"
SV / SV-DLE 1012/604	1 1/4"
SV / SV-DLE 1015/604	1 1/2"
SV / SV-DLE 1020/604	2"

Gases

Natural gas, propane, butane; other noncorrosive gases. When used with manufactured gases, quarterly leak checks are required. Suitable for dry, 0.1% by volume H₂S.

Maximum Operating Pressure

10 PSI (700 mbar)

Maximum Close Off Pressure

15 PSI (1000 mbar)

Ambient / Fluid Temperature

-40°F to +140°F; (-40°C to +60°C)

Electrical Ratings Available

120 Vac - 50 to 60 Hz

Enclosure Rating

NEMA Type 4 for indoor applications
NEMA Type 12 for outdoor applications

Power Consumption

SV / SV-DLE 1005/604	20VA
SV / SV-DLE 1007/604	20VA
SV / SV-DLE 1010/604	25VA
SV / SV-DLE 1012/604	25VA
SV / SV-DLE 1015/604	45VA
SV / SV-DLE 1020/604	45VA

Electrical Connection

DIN-Connector with 1/2" NPT conduit adapter.

Operating Time

100 % duty cycle

Closing Time

< 1 second

Opening Time

SV/604: < 1 sec.

SV-DLE/604: 10 to 20 sec. (70 °F)

Max. Flow Adjustment (SV-DLE/604)

Adjustable: 0 to 100 % of total flow. When adjusted to low flows, flow repeatability upon opening is +/-15%.

Initial Lift Adjustment (SV-DLE/604)

Adjustable: 0 to 70 % of total flow; 0 to 35% of stroke

Materials in contact with Gas

Housing: Aluminum & Steel, free of non-ferrous metals
Sealings on valve seats: NBR-based rubber

Mounting Position

Solenoid upright vertical
to solenoid horizontal

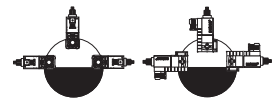

Strainer

23 Mesh, installed in the housing upstream valve seat

Test Ports

G 1/8 ISO 228 taps available on both sides upstream and downstream of valve seat, on inlet and outlet of SV also on flange (SV 1010-1020 only). See Page 4 for details.

Approvals

CSA: Certified File No.1350312
FM Approved: Report 3014562
Commonwealth of Massachusetts Approved Product
Approval code G1-1107-35



ATTENTION

- Read these instructions carefully.
- Failure to follow them and/or improper installation may cause explosion, property damage and injuries.
- The system must meet all applicable national and local code requirements such as but not limited to the following fuel gas codes: NFPA 54, IFGC (International Fuel Gas Code), or CSA B149.1 (for Canada) or the following equipment codes and standards: CSD-1, NFPA 86, ANSI Z83.4/CSA 3.7, ANSI Z83.18, ANSI Z21.13/ CSA 4.9, or CSA B149.3 (for Canada).
- Installation must be done with the supervision of a licensed burner technician.
- Check the ratings in the specifications to make sure that they are suitable for your application.
- Never perform work if gas pressure or power is applied, or in the presence of an open flame.
- Once installed, perform a complete checkout including leak testing.
- Verify proper operation after servicing.

MOUNTING

Recommended Preparation

- Examine the SV-(DLE) for shipping damage.
- The main gas supply must be shut off before installing the valve.
- The inside of the SV-(DLE), the flange, and piping must be clean and free of dirt and debris before installing. Failure to remove dirt and debris could result in valve damage and/or improper performance.

Flange Mounting Procedure

- Verify that the o-ring and the groove is clean and in good condition on the outlet side of the valve.
- Install the SV-(DLE) with the gas flow matching the direction indicated by the arrows on the casting.
- Mount the SV-(DLE) with the solenoid vertical upright to horizontal.
- Clean the mounting surface of the flange.
- Attach the flange to the outlet of the SV-(DLE) using the screws supplied.
- Use a 4mm Allen wrench for the M5 screw.
SV / SV-DLE1005 & 1007
- Use a 5mm Allen wrench for the M6 screw.
SV / SV-DLE 1010, 1012
- Use a 6mm Allen wrench for the M8 screw.
SV / SV-DLE 1015, 1020
- Tighten the screws in a crisscross pattern
- Do not overtighten the screws. Follow the maximum torque values below.

Recommended Torque

M5	M6	M8	Screw Size
44	62	134	[lb-in]

Recommended Piping Procedure

- Use new, properly reamed and threaded pipe.
- Apply good quality pipe sealant, putting a moderate amount on the male threads only. If pipe sealant lodges on the valve seat, it will prevent proper operation. If using LP gas, use pipe sealant rated for use with LP gas.
- Do not thread pipe too far. Valve distortion and/or malfunction may result from excess pipe in the valve body.
- Apply counter pressure with a parallel jaw wrench only to the flats on the flange when connecting to pipe.
- Do not overtighten the pipe. Follow the maximum torque values listed below.

Recommended Torque for Gas Piping

1/2"	3/4"	1"	1-1/4"	1-1/2"	2"	NPT pipe
375	560	750	875	940	1190	[lb-in]

- After installation, perform a complete leak test using a soapy solution. The presence of bubbles indicates a leak.

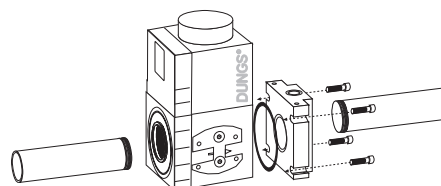

If the flow is not in the same direction of the arrows on the valve body, the valve will not operate properly.

PAINTING VALVE

- It is not recommended that this valve be painted. Painting covers date codes and other labels that identify this valve.
- If the valve needs to be painted, a paint free of volatile organic components (VOC's) must be used. VOC's can damage valve o-rings, resulting in external gas leakage over time.
- During the painting process, use measures that will allow the valve's date code and other labeling information to be legible after the paint is dry.

PROTECTION FROM RADIANT HEAT

- Radiant heat must be considered as a heat source that could result in an ambient temperature higher than the rating of this valve.
- Provide proper shielding to protect against radiant heat.

WIRING

Wiring the SV-(DLE)

- Disconnect all power to the valves before wiring to prevent electrical shock and equipment damage.
- Do not exceed the electrical ratings given in the specifications and on the valve.
- Attach flexible 1/2" NPT conduit to the DIN connector.
- Route the wires through the conduit and the DIN connector.

DIN Connector Terminals

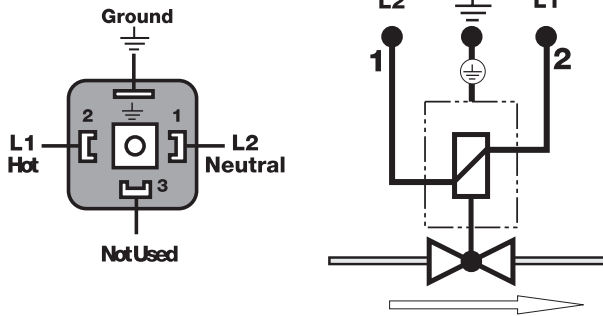

- Use 14 or 16 gauge wire rated for at least 75°C (167°F).
- Connect the wiring to the appropriate screw terminals in the DIN connector.
- Plug the DIN connector onto the terminals. Fasten the DIN connector with the screw supplied.



CAUTION: All wiring must comply with local electrical codes, ordinances and regulations.

VALVE ADJUSTMENT

Max. Flow Adjustment (SV-DLE only)

- The SV-DLE is factory set with the max. flow adjustment fully open.



Before making a max. flow adjustment, the valve should be properly piped in the application.

- Locate the max. flow adjustment on top of the SV-DLE (base of the hydraulic brake). There are two screws, the holding screw is recessed and has a blue sealing compound on it, while the pan head screw protrudes from the cap.
- Loosen the pan head screw until you can freely rotate the flow adjustment.
- Turn clockwise for less gas or counterclockwise for more gas.
- Check the flow at the burner with an orifice or flow meter.
- Tighten the pan head screw on the adjustment cap after adjustments are completed.

Initial Lift Adjustment (SV-DLE only)

The initial lift adjustment varies the initial gas flow through the valve as the valve seat begins to open. This adjustment can allow the initial gas flow to 0 % and 70% of the total gas flow; 0 to 25% of stroke, within 1 second. All SV-DLE valves are factory set with no initial lift (100% slow opening). To adjust the lift proceed as follows:

- Unscrew the small black cap on top of the flow adjustment cap to expose the initial lift adjustment knob.
- The black cap also serves as tool; turn the cap over and insert it on the slot on the adjustment knob.
- Turn the knob clockwise for a min. initial lift or counterclockwise for a max. initial lift.
- Once the desired initial fast lift has been achieved, reinstall the black cap.

Max. Flow Setting

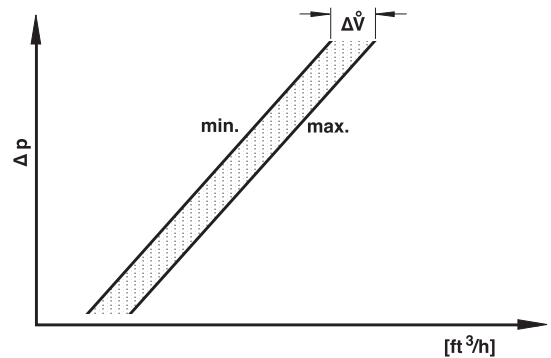

Initial Lift Adjustment

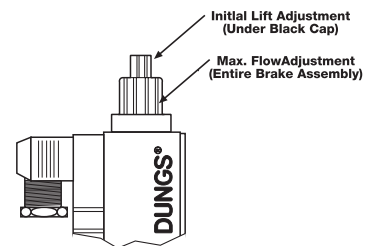
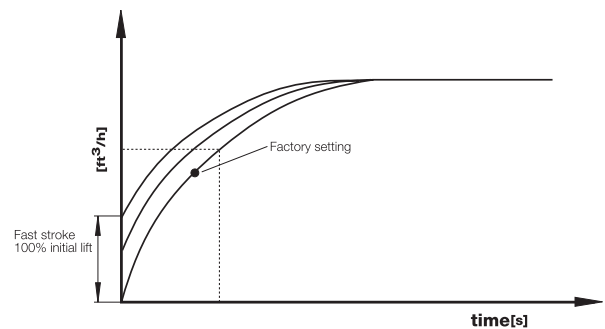

Do not adjust or remove any screws or bolts which are sealed with a Red colored compound. Doing so will void all approvals and warranties.

TEST PORTS

Test Ports

G1/8 ISO 228 test ports available on both sides of the valve. Each side has one test port upstream (2), one downstream (3) of the valve seat. One Inlet (1) and outlet (4) of valve body. The SV 1010, 1012, 1015, and 1020 have one outlet (5) on valve flange. The G 1/8 test nipple (# 219-008) can be screwed into any of the test ports.

⚠ The position of the side taps #2 and #3 on the SV 1005/1007 are not the same as on the SV 1010-1020 valves.

SV-(DLE): 1005, 1007

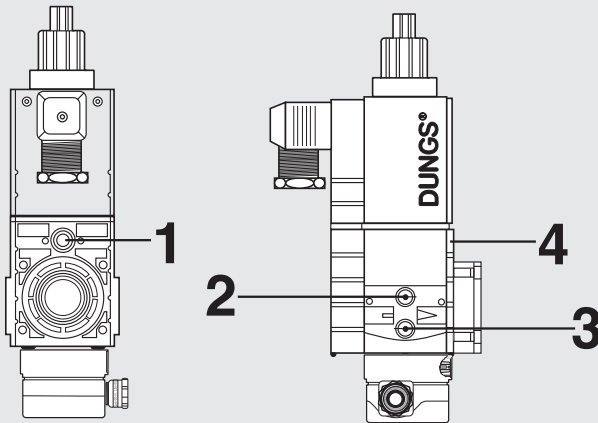
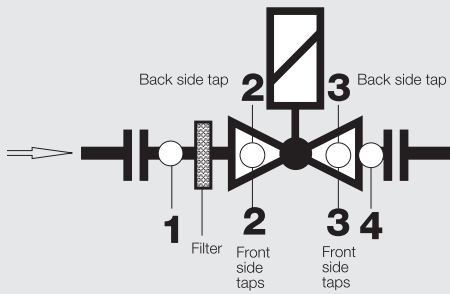

SV-(DLE): 1010, 1012

SV-(DLE): 1015, 1020

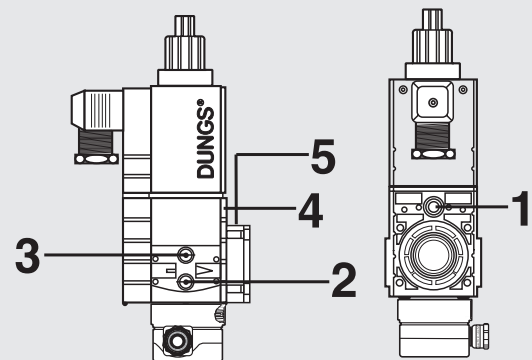
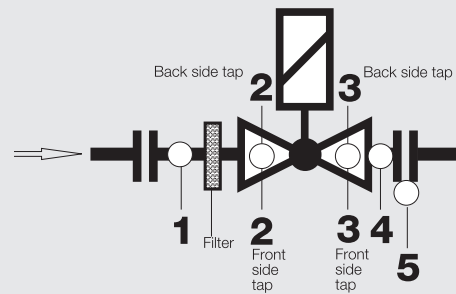

VALVE LEAKAGE TEST

This leak test procedure tests the external sealing and valve seat sealing capabilities of two SV automatic safety shutoff valves in series. Only qualified personnel should perform this test.

It is required that this test be done on the initial system start-up, and then repeated at least annually. Possibly more often depending on the application, environmental parameters, and the requirements of the authority having jurisdiction.

SETUP

This test requires the following:

- A) Test nipples installed in the downstream pressure tap port of each automatic safety shutoff valve to make the required 1/4" hose connection in step 4.
- B) A transparent glass of water filled at least 1 inch from the bottom.
- C) A proper leak test tube. An aluminum or copper 1/4" rigid tube with a 45° cut at the end that is then connected to a 1/4" flexible hose of some convenient length provides for a more accurate leakage measurement. However, a 45° cut at the end of the 1/4" flexible hose will suffice, but it will not likely be as accurate as the rigid tube.
- D) For detecting external leakages, an all purpose liquid leak detector solution or a soapy water solution is required.

LEAK TEST PROCEDURE

Use the illustration below as a reference.

1. With the upstream ball valve open, the downstream ball valve closed and both valves energized, apply an all purpose liquid leak detector solution to the "External Leakage Test Areas" indicated in the illustration below, to any accessories mounted to the safety valve, and to all gas piping and gas components downstream the equipment

isolation valve, and the inlet and outlet gas piping for each automatic safety shutoff valve. The presence of bubbles indicates a leak, which needs to be rectified before proceeding.

2. Then, de-energize the burner system and verify that both automatic safety shutoff valves are closed.
3. Close the upstream and downstream manual ball valve.
4. Open the downstream test nipple of the upstream valve, and connect the 1/4" flexible hose to the test nipple.
5. Slowly open the upstream manual ball valve, and then provide for some time to allow potential leakage to charge the test chamber before measuring the valve seat leakage.
6. Immerse the 1/4 in. tube vertically 1/2 in. (12.7 mm) below the water surface. If bubbles emerge from the 1/4" tube and after the leakage rate has stabilized, count the number of bubbles appearing during a 10 second period. (See chart below for allowable leakage rates.)
7. Repeat the procedure for the downstream automatic safety shutoff valve except that valve #1 needs to be opened during the leakage test.

After completing the above tests proceed as follows:

8. Verify that the downstream manual ball valve is closed, and both automatic safety shutoff valves are de-energized.
9. Remove the flexible hose, and close all test nipples.
10. With the upstream manual ball valve open, energize both automatic safety shutoff valves.
11. Use soapy water to leak test all test nipples to ensure that there are no leaks.
12. If no leakage is detected, de-energize all automatic safety shutoff valves, and open the downstream manual ball valve.



WARNING: If leakage values are exceeded, replace valve immediately.



NOTE: The position of the side taps #2 and #3 on the SV 1005/1007 are not the same as on the SV 1010-1020 valves.

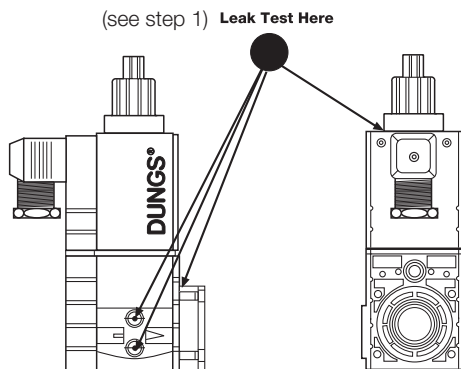

SV-(DLE): 1005, 1007

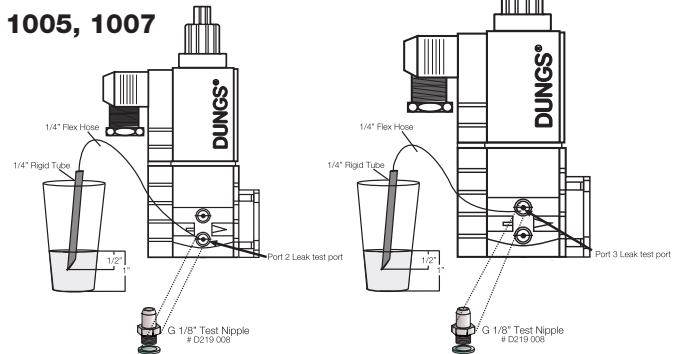

SV-(DLE): 1010, 1012, 1015, 1020

Valve Type	Allowable Valve Seat Leakage* for up to 10 PSI inlet	# of Bubbles in 10 Sec.		
		AIR	Natural Gas	LP
SV-(DLE) 1005/1007	239cc/hr	5	6	4
SV-(DLE) 1010/1012	464 cc/hr	9	11	7
SV-(DLE) 1015/1020	588 cc/hr	10	12	8

*Based on air, and test conditions per UL 429 Section 29. (Air or inert gas at a pressure of 1/4 psig and also at a pressure of one and one-half times maximum operating pressure differential, but not less than 1/2 psig. This test shall be applied with the valve installed in its intended position.) Volume of bubble defined in Table 2 of FCI 70-2-1998.

FLOW CURVE

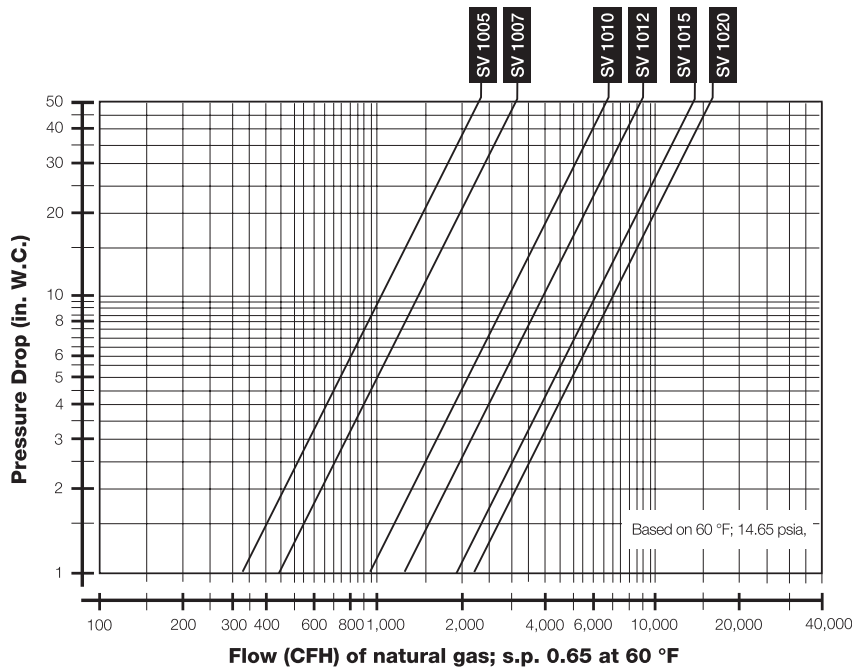

PRESSURE DROP FOR OTHER GASES

To determine the pressure drop when using a gas other than natural gas, use the flow formula below and f value located in the chart below to determine the “corrected” flow rate in CFH through the valve for the other gas used. For example, when using propane, divide the volume (CFH) of propane required for the application by the calculated value f (f = 0.66 for propane). Use this “corrected” flow rate and the flow curve above to determine pressure drop for propane.

$$\dot{V}_{\text{gas used}} = \dot{V}_{\text{Natural Gas}} \times f$$

Use this formula to calculator the f factor for other gases not listed on the table.

$$f = \sqrt{\frac{\text{Spec. gravity of Natural Gas}}{\text{Spec. gravity of gas used}}}$$

Type of gas used	Density [kg/m ³]	sg	f
Natural gas	0.81	0.65	1.00
Butane	2.39	1.95	0.58
Propane	1.86	1.50	0.66
Air	1.24	1.00	0.80

REPLACEMENT PARTS

Valve	Pipe Size	Replacement Coil (120Vac)	Part # NPT Flange Kit*	Part # Rp Flange Kit*	Part # PCB Board	Electrical Plug (Hirschmann) 210-319
SV 1005 / 1007	1/2	246-502	242-650	242-220	245-147	
SV 1005 / 1007	3/4	246-502	242-651	242-221	245-147	
SV 1010 / 1012	1/2	246-503	242-653	242-223	245-153	M20-1/2" NPT adapter 240-671
SV 1010 / 1012	3/4	246-503	242-654	242-224	245-153	
SV 1010 / 1012	1	246-503	242-655	242-225	245-153	
SV 1010 / 1012	1 1/4	246-503	242-656	242-226	245-153	
SV 1015 / 1020	1	246-504	242-657	242-227	245-153	Valve Indicator 217-665
SV 1015 / 1020	1 1/4	246-504	242-658	242-228	245-153	
SV 1015 / 1020	1 1/2	246-504	242-659	242-229	245-153	
SV 1015 / 1020	2	246-504	242-660	242-230	245-153	

* Mounting kit includes 1 flange, 4 bolts and 1 O-ring.